

14 Exploded View

CS-XE9CKE CS-XE12CKE

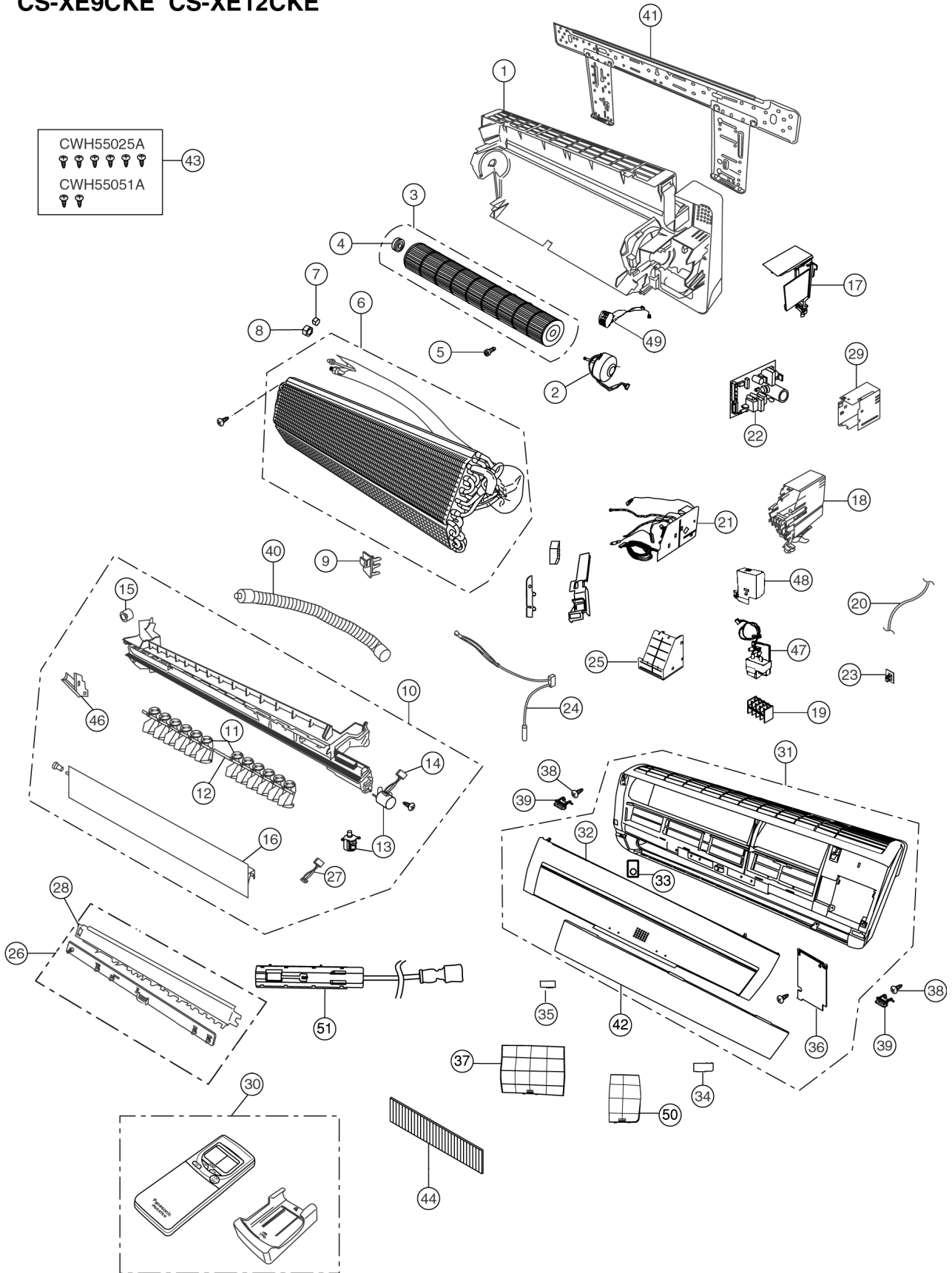

Note:
 The above exploded view is for the purpose of parts disassembly and replacement.
 The non-numbered parts are not kept as standard service parts.

15 Replacement Parts List

<Model: CS-XE9CKE CS-XE12CKE>

REF. NO.	PART NAME & DESCRIPTION	QTY.	CS-XE9CKE	CS-XE12CKE	REMARKS
1	CHASSY COMPLETE	1	CWD50C1246	←	
2	FAN MOTOR	1	CWA981121	←	0
3	CROSS FLOW FAN COMPLETE	1	CWH02C1028	←	
4	BEARING ASS'Y	1	CWH64K007	←	
5	SCREW - CROSS FLOW FAN	1	CWH4580304	←	
6	EVAPORATOR	1	CWB30C1439	CWB30C1438	
7	FLARE NUT	1	CWT25086 (1/4")	←	
8	FLARE NUT	1	CWT25087 (3/8")	CWT25096 (1/2")	
9	INTAKE AIR SENSOR HOLDER	1	CWH32142	←	
10	DISCHARGE GRILLE COMPLETE	1	CWE20C2280	←	
11	VERTICAL VANE	12	CWE241088	←	
12	CONNECTING BAR	1	CWE261035	←	
13	AIR SWING MOTOR	2	CWA98260	←	0
14	LEAD WIRE - AIR SWING MOTOR	1	CWA67C3977	←	
15	CAP - DRAIN TRAY	1	CWH52C1001	←	
16	HORIZONTAL VANE	1	CWE241070A	←	
17	BACK COVER CHASSIS	1	CWD932162	←	
18	CONTROL BOARD CASING	1	CWH102103	←	
19	TERMINAL BOARD COMPLETE	1	CWA28C2128	←	0
20	POWER SUPPLY CORD	1	CWA20C2208	←	
21	ELECTRONIC CONTROLLER - MAIN	1	CWA73C1594	CWA73C1595	0
22	ELECTRONIC CONTROLLER - P. SUPPLY	1	CWA743304	←	0
23	ELECTRONIC CONTROLLER - RECEIVER	1	CWA742724	←	0
24	SENSOR COMPLETE	1	CWA50C2122	←	0
25	CONTROL BOARD FRONT COVER	1	CWH131090	←	
26	ELECTRONIC CONTROLLER - INDICATOR	1	CWE39C1107	←	0
27	LEAD WIRE - AIR SWING MOTOR	1	CWA67C3849	←	
28	INDICATOR HOLDER	1	CWD932338	←	
29	CONTROL BOARD TOP COVER	1	CWH131091	←	
30	REMOTE CONTROL COMPLETE	1	CWA75C2428	←	0
31	FRONT GRILLE COMPLETE	1	CWE11C3018	←	0
32	INTAKE GRILLE	1	CWE22C1125	←	
33	CONTROL PANEL	1	CWE312421	←	
34	DECORATION BASE (R)	1	CWE351075	←	
35	DECORATION BASE (L)	1	CWE351076	←	
36	GRILLE DOOR	1	CWE141064	←	
37	AIR FILTER	1	CWD001053	←	
38	SCREW - FRONT GRILLE	2	XTN4+16C	←	
39	CAP - FRONT GRILLE	2	CWH521062A	←	
40	DRAIN HOSE	1	CWH85285	←	
41	INSTALLATION PLATE	1	CWH36K1018	←	
42	FRONT PANEL ASS'Y	1	CWE13K1005	←	
43	BAG COMPLETE - INSTALLATION SCREW	1	CWH82C067	←	
44	AIR PURIFYING FILTER	1	CWMD00C0001	←	0
46	FULCRUM	1	CWH621013	←	
47	ELECTRONIC CONTROLLER - IONIZER	1	CWA743099	←	0
48	CASING - IONIZER	1	CWD932228	←	
49	ION GENERATOR	1	CWH94C0001	←	
50	AIR FILTER	1	CWD001054	←	
51	BOX SHAPED PIECE COMPLETE	1	CWD76C1027	←	

(Note)

- All parts are supplied from MAICO, Malaysia (Vendor Code: 061).
- "O" marked parts are recommended to be kept in stock.

16 Exploded View

CU-XE9CKE CU-XE12CKE

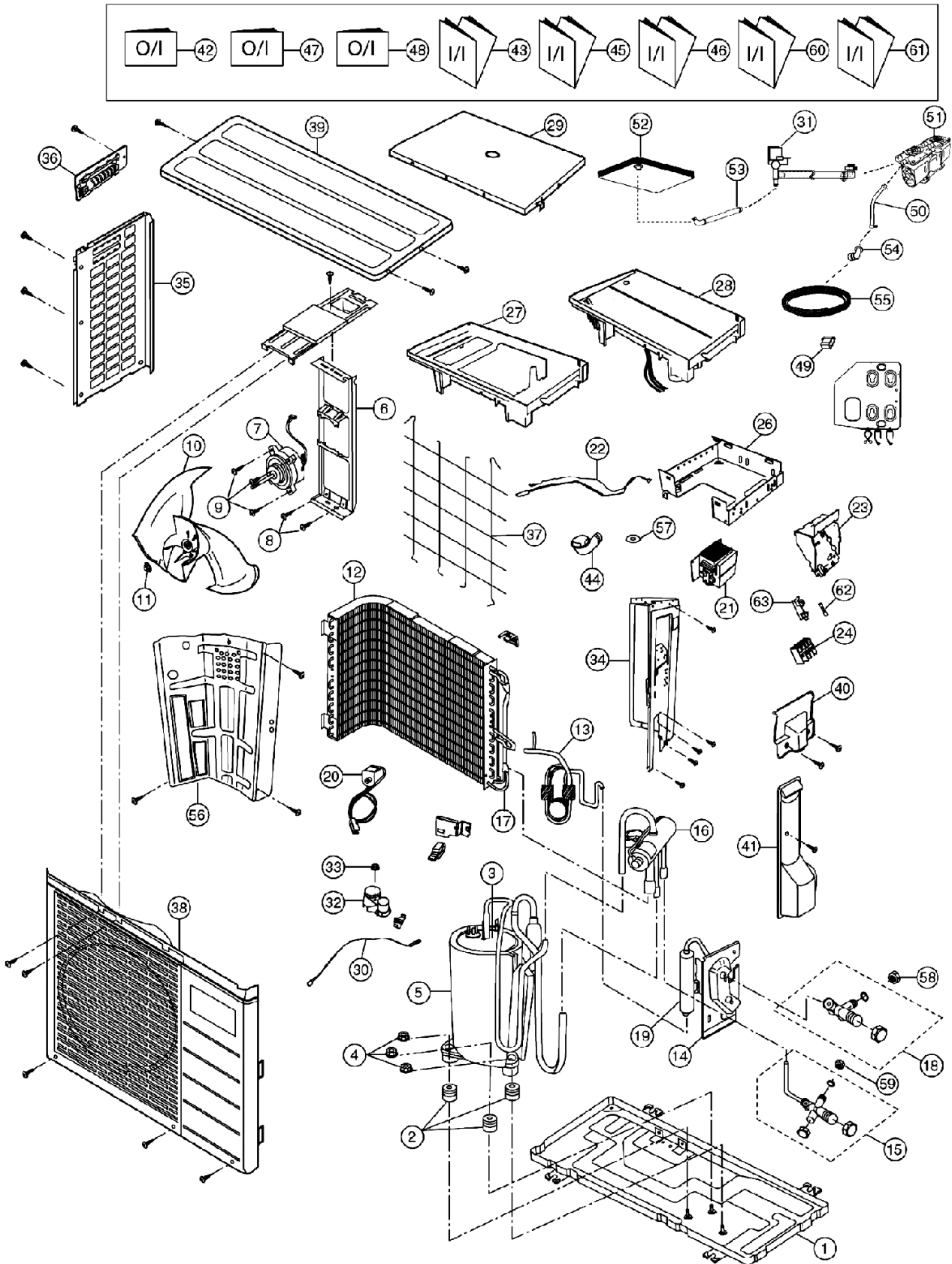

Note:

The above exploded view is for the purpose of parts disassembly and replacement.

The non-numbered parts are not kept as standard service parts.

17 Replacement Parts List

<Model: CU-XE9CKE CU-XE12CKE>

REF NO.	DESCRIPTION & NAME	QTY.	CU-XE9CKE	CU-XE12CKE	REMARKS
1	CHASSY ASSY	1	CWD50K2073	←	
2	ANTI-VIBRATION BUSHING	3	CWH50077	←	
3	COMPRESSOR	1	5CS102XEC	←	O
4	NUT-COMPRESSOR MOUNT	3	CWH56000	←	
5	SOUND PROOF MATERIAL	1	CWG302111	←	
6	FAN MOTOR BRACKET	1	CWD541030	←	
7	FAN MOTOR	1	CWA951321	CWA951309	O
8	SCREW - FAN MOTOR BRACKET	2	CWH551060	←	
9	SCREW - FAN MOTOR MOUNT	4	CWH55406	←	
10	PROPELLER FAN ASSY	1	CWH03K1006	←	
11	NUT - PROPELLER FAN	1	CWH56053	←	
12	CONDENSER	1	CWB32C1145	CWB32C1146	
13	TUBE ASS'Y (CAPILLARY TUBE)	1	CWT01C2360	CWT01C2361	
14	HOLDER-COUPLING	1	CWH351023	←	
15	3 WAYS VALVE (GAS)	1	CWB011074	CWB011075	O
16	4 WAYS VALVE	1	CWB001011	←	
17	TUBE ASS'Y (STRAINER)	1	CWT023220	←	
18	2 WAYS VALVE (LIQUID)	1	CWB021064	←	O
19	DRYER	1	CWB101015	←	O
20	V-COIL COMPLETE	1	CWA43C2072	←	
21	REACTOR	1	CWA421050	CWA421051	
22	SENSOR COMPLETE	1	CWA50C2115	←	
23	CONTROL BOARD CASING (SIDE)	1	CWH102122	←	
24	TERMINAL BOARD ASSY	1	CWA28K1036	←	
26	CONTROL BOARD CASING (BOTTOM)	1	CWH102114	←	
27	CONTROL BOARD CASING (TOP)	1	CWH102115	←	
28	ELECTRONIC CONTROLLER - MAIN	1	CWA73C1596R	CWA73C1597R	O
29	CONTROL BOARD COVER (TOP)	1	CWH131104	←	
30	SENSOR COMPLETE	1	CWA50C2066	←	
31	2-WAY VALVE COMPLETE (OXYGEN PUMP)	1	CWB02C1008	←	O
32	TERMINAL COVER	1	CWH171001	←	
33	NUT-TERMINAL COVER	1	CWH7080300	←	
34	CABINET SIDE PLATE CO.	1	CWE04C1036	←	
35	CABINET SIDE PLATE (LEFT)	1	CWE041031A	←	
36	HANDLE	1	CWE161010	←	
37	WIRE NET	1	CWD041053A	CWD041054A	
38	CABINET FRONT PLATE CO.	1	CWB06C1039	←	
39	CABINET TOP PLATE	1	CWE031014A	←	
40	CONTROL BOARD COVER	1	CWH131110	←	
41	CONTROL BOARD COVER CO.	1	CWH13C1064	←	
42	OPERATING INSTRUCTION (ENG., FRA., NED. & DEU.)	1	CWF564320	←	
43	INSTALLATION INSTRUCTION (ENG., FRA., ESP. & DEU.)	1	CWF612574	←	
44	L-TUBE	1	CWH5850080	←	
45	INSTALLATION INSTRUCTION (ITA., NED., POR. & GRE.)	1	CWF612575	←	
46	INSTALLATION INSTRUCTION (RUS.)	1	CWF612576	←	
47	OPERATION INSTRUCTION (ENG., ITA., POR. & ESP.)	1	CWF564321	←	
48	OPERATION INSTRUCTION (ENG., BUL., GRE. & RUS.)	1	CWF564322	←	
49	CAPACITOR - VACUUM PUMP (1.2µF, 440 VAC)	1	DS441125BLQA	←	
50	FLEXIBLE PIPE COMPLETE	1	CWH85C1021	←	
51	VACUUM PUMP	1	CWB532034	←	O
52	FILTER - OXYGEN GENERATOR	1	CWD071010	←	O
53	FLEXIBLE PIPE COMPLETE	1	CWH851087	←	
54	TUBE CONNECTOR COMPLETE	1	CWT29C1021	←	
55	FLEXIBLE PIPE COMPLETE	1	CWH85C1013	←	
56	SOUND PROOF BOARD	1	CWH151071	←	
57	PACKING-L TUBE	1	CWB81012	←	
58	FLARE NUT	1	CWT25086 (1/4")	←	
59	FLARE NUT	1	CWT25087 (3/8")	CWT25096 (1/2")	
60	INSTALLATION INSTRUCTION OXYGEN TUBE	1	CWF612597	←	
61	INSTALLATION INSTRUCTION OXYGEN TUBE	1	CWF612598	←	
62	FUSE CAP TERMINAL	1	K5D203BBA002	←	O
63	FUSE HOLDER	1	K3GB1PH00016	←	O

(Note)

- All parts are supplied from MAICO, Malaysia (Vendor Code: 061).
- "O" marked parts are recommended to be kept in stock.