

18 Exploded View and Replacement Parts List

18.1. Indoor Unit

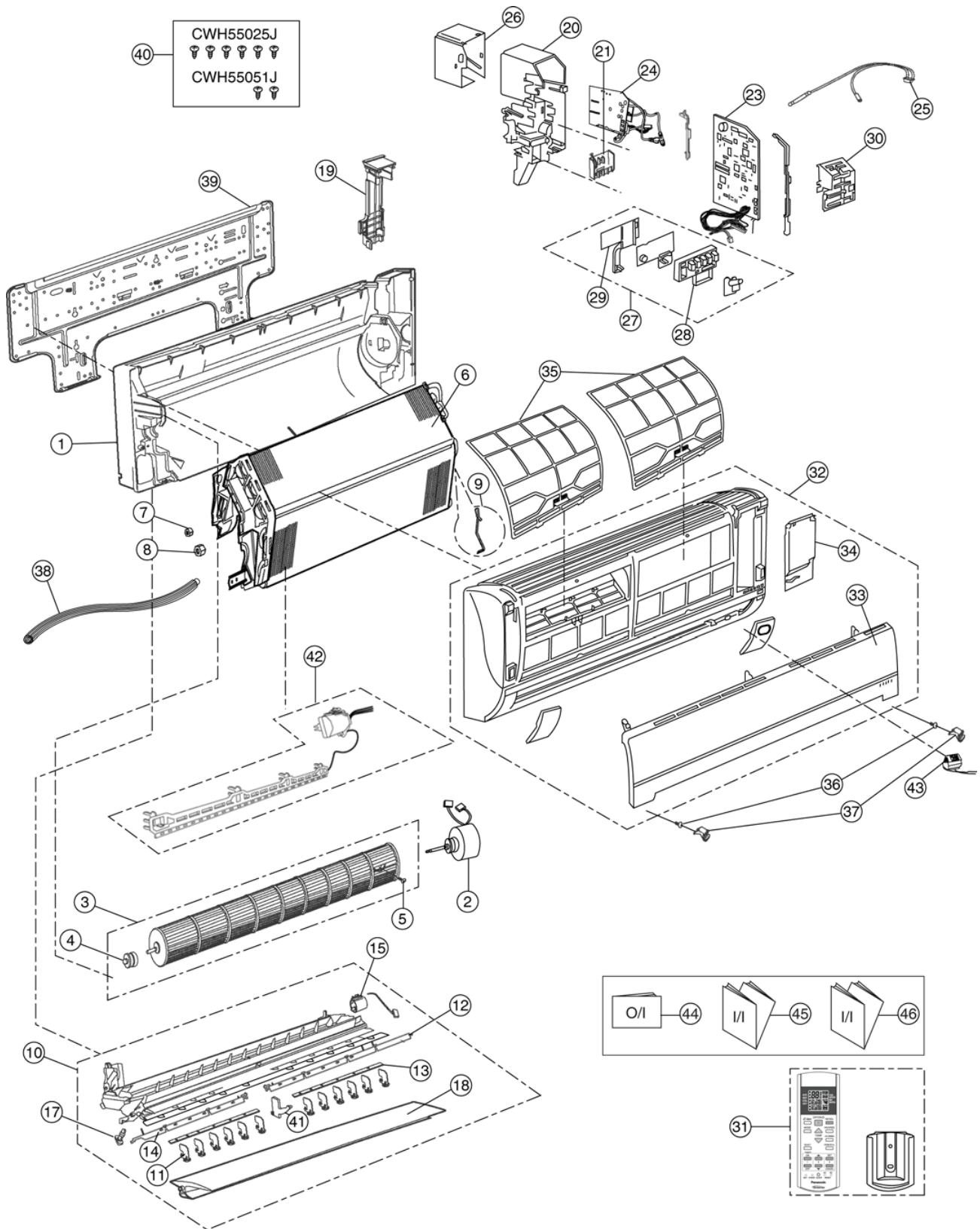

Note
 The above exploded view is for the purpose of parts disassembly and replacement.
 The non-numbered parts are not kept as standard service parts.

REF. NO.	PART NAME & DESCRIPTION	QTY.	CS-CE7HKEW	CS-CE9HKEW	CS-CE12HKEW	REMARKS
1	CHASSY COMPLETE	1	CWD50C1572	←	←	
2	FAN MOTOR	1	ARW61F8P30AC	←	←	O
3	CROSS FLOW FAN COMPLETE	1	CWH02C1045	←	←	
4	BEARING ASSY	1	CWH64K007	←	←	
5	SCREW - CROSS FLOW FAN	1	CWH551146	←	←	
6	EVAPORATOR	1	CWB30C2484	CWB30C2386	CWB30C2389	
7	FLARE NUT (1/4")	1	CWT251030	←	←	
8	FLARE NUT (3/8") (1/2")	1	CWT251031	←	CWT251032	
9	CLIP FOR SENSOR	1	CWH32143	←	←	
10	DISCHARGE GRILLE COMPLETE	1	CWE20C2621	←	←	
11	VERTICAL VANE	12	CWE241157	←	←	
12	CONNECTING BAR	1	CWE261092	←	←	
13	CONNECTING BAR	2	CWE261071	←	←	
14	CONNECTING BAR	1	CWE261091	←	←	
15	AIR SWING MOTOR	1	CWA981091	←	←	O
17	CAP - DRAIN TRAY	1	CWH521096	←	←	
18	HORIZONTAL VANE COMPLETE	1	CWE24C1176	←	←	
19	BACK COVER CHASSIS	1	CWD932454	←	←	
20	CONTROL BOARD CASING	1	CWH102321	←	←	
21	TERMINAL BOARD COMPLETE	1	CWA28C2305	←	←	O
23	ELECTRONIC CONTROLLER - MAIN	1	CWA73C2957	CWA73C3018	CWA73C3019	O
24	ELECTRONIC CONTROLLER - POWER	1	CWA745131	←	←	O
25	SENSOR COMPLETE	1	CWA50C2122	←	←	O
26	CONTROL BOARD FRONT COVER	1	CWH131207	←	←	
27	INDICATOR COMPLETE	1	CWE39C1168	←	←	O
28	INDICATOR HOLDER	1	CWD932744	←	←	
29	INDICATOR HOLDER	1	CWD932745	←	←	
30	CONTROL BOARD FRONT COVER CO.	1	CWH13C1171	←	←	
31	REMOTE CONTROL CO.	1	CWA75C3177	←	←	O
32	FRONT GRILLE COMPLETE	1	CWE11C3896	←	←	O
33	INTAKE GRILLE COMPLETE	1	CWE22C1415	←	←	
34	GRILLE DOOR COMPLETE	1	CWE14C1010	←	←	
35	E-ION FILTER	2	CWD00K1004	←	←	
36	SCREW - FRONT GRILLE	2	XTT4+16CFJ	←	←	
37	CAP - FRONT GRILLE	2	CWH521109	←	←	
38	DRAIN HOSE	1	CWH851063	←	←	
39	INSTALLATION HOLDER	1	CWH361067	←	←	
40	BAG COMPLETE - INSTALLATION SCREW	1	CWH82C067	←	←	
41	FULCRUM	1	CWH621049	←	←	
42	E-ION AIR PURIFYING SYSTEM	1	CWH14C5332	←	←	O
43	ION - GENERATOR	1	CWH94C0014	←	←	O
44	OPERATION INSTRUCTIONS	1	CWF565860	←	←	
45	INSTALLATION INSTRUCTIONS (ENG)	1	CWF613375	←	←	
46	INSTALLATION INSTRUCTIONS (SWE, NOR, DAN, FIN)	1	CWF613376	←	←	

(NOTE)

- All parts are supplied from PHAAM, Malaysia (Vendor Code: 061).
- "O" marked parts are recommended to be kept in stock.

18.2. Outdoor Unit

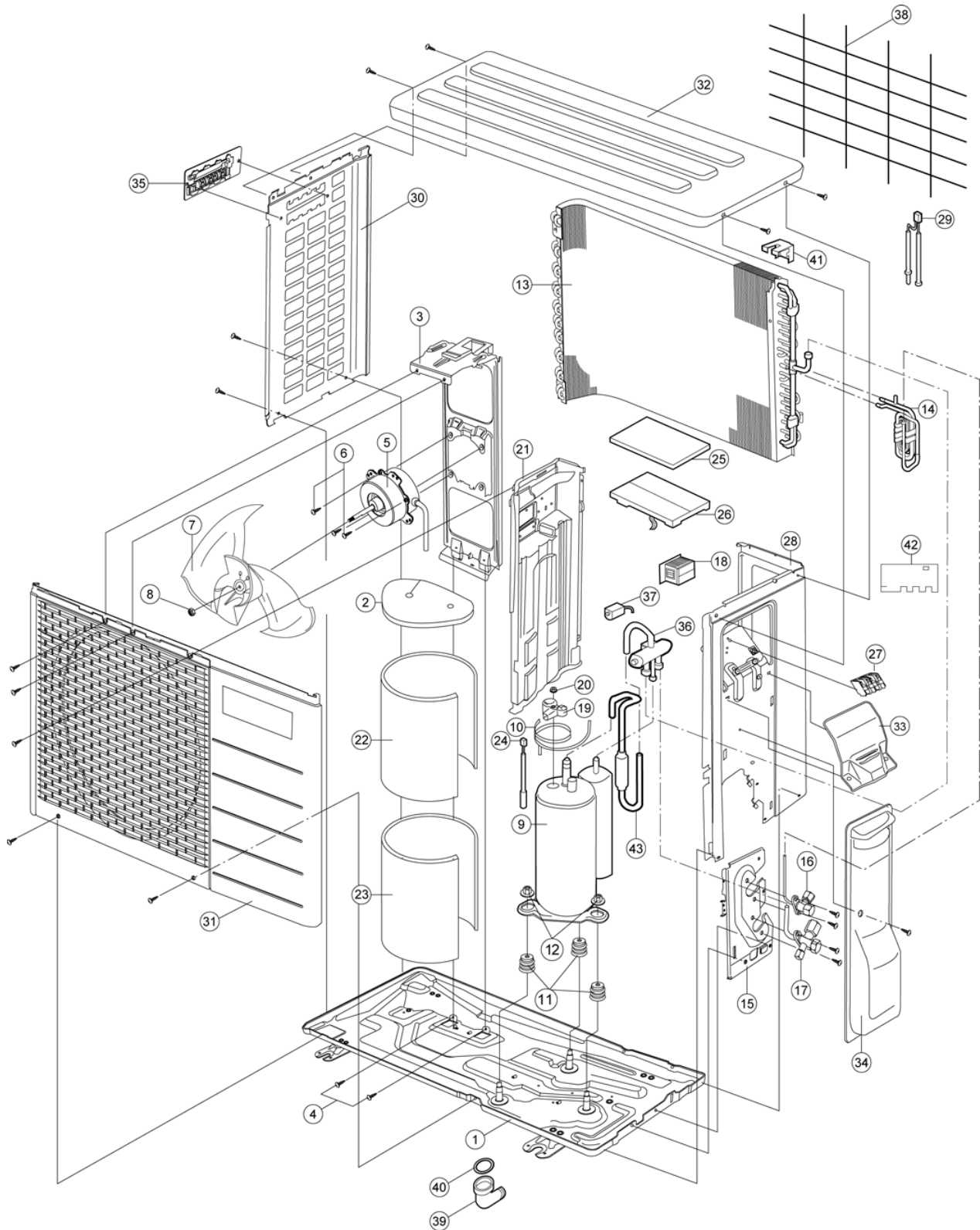

Note

The above exploded view is for the purpose of parts disassembly and replacement.
The non-numbered parts are not kept as standard service parts.

REF. NO.	PART NAME & DESCRIPTION	QTY.	CU-CE7HKE	CU-CE9HKE	CU-CE12HKE	REMARKS
1	CHASSY ASS'Y	1	CWD50K2073	←	←	
2	SOUND PROOF MATERIAL	1	CWG302314	←	←	
3	FAN MOTOR BRACKET	1	CWD541030	←	←	
4	SCREW - FAN MOTOR BRACKET	2	CWH551217	←	←	
5	FAN MOTOR	1	CWA951536	CWA951553	CWA951542	O
6	SCREW - FAN MOTOR MOUNT	3	CWH55252J	←	←	
7	PROPELLER FAN ASS'Y	1	CWH03K1010	←	←	
8	NUT - PROPELLER FAN	1	CWH56053J	←	←	
9	COMPRESSOR	1	5RS092XCD01	5RS102XBC01	←	O
10	CRANKCASE HEATER	1	CWA341044	←	←	
11	ANTI - VIBRATION BUSHING	3	CWH50077	←	←	
12	NUT - COMPRESSOR MOUNT	3	CWH56000J	←	←	
13	CONDENSER	1	CWB32C2485	CWB32C2446	←	
14	TUBE ASS'Y CO. (CAP. / CHK VALVE)	1	CWT01C4051	CWT01C4201	CWT01C4202	
15	HOLDER COUPLING	1	CWH351023	←	←	
16	2-WAYS VALVE (LIQUID)	1	CWB021301	←	←	O
17	3-WAYS VALVE (GAS)	1	CWB011374	←	CWB011367	O
18	REACTOR	1	G0C193J00003	←	G0C193J00004	O
19	TERMINAL COVER	1	CWH171039A	←	←	
20	NUT - TERMINAL COVER	1	CWH7080300J	←	←	
21	SOUND PROOF BOARD	1	CWH151172	←	←	
22	SOUND PROOF MATERIAL	1	CWG302316	←	←	
23	SOUND PROOF MATERIAL	1	CWG302317	←	←	
24	SENSOR COMPLETE	1	CWA50C2205	←	←	O
25	CONTROL BOARD COVER	1	CWH131264	←	←	
26	ELECTRONIC CONTROLLER - MAIN	1	CWA73C3147R	CWA73C3148R	CWA73C3149R	O
27	TERMINAL BOARD ASS'Y	1	CWA28K1110J	←	←	O
28	CABINET SIDE PLATE CO.	1	CWE04C1116	←	←	
29	SENSOR COMPLETE	1	CWA50C2391	←	←	O
30	CABINET SIDE PLATE	1	CWE041248A	←	←	
31	CABINET FRONT PLATE CO.	1	CWE06C1039	CWE06C1136	←	
32	CABINET TOP PLATE	1	CWE031014A	←	←	
33	PLATE - C. B. COVER	1	CWH131301	←	←	
34	CONTROL BOARD COVER CO.	1	CWH13C1064	←	←	
35	HANDLE	1	CWE161010	←	←	
36	4-WAYS VALVE	1	CWB001037J	←	←	O
37	V - COIL COMPLETE	1	CWA43C2143J	←	←	O
38	WIRE NET	1	CWD041111A	←	←	
39	L - TUBE	1	CWH5850080	←	←	
40	PACKING - L. TUBE	1	CWB81012	←	←	
41	HOLDER SENSOR	1	CWH321023	←	←	
42	SOUND PROOF MATERIAL	1	CWG302315	←	←	
43	DISCHARGE MUFFLER	1	CWB121010	←	←	

(NOTE)

- All parts are supplied from PHAAM, Malaysia (Vendor Code: 061).
- "O" marked parts are recommended to be kept in stock.